

Automatic Veterinary Syringes

ThaMa 405

Fix Dosage 0.1 cc

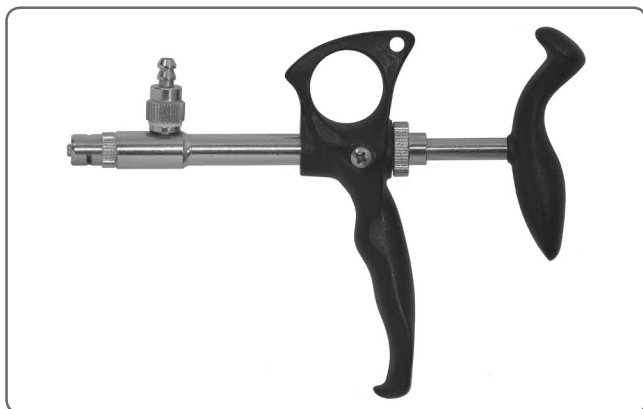

Operating Instructions:

This Automatic Syringe ThaMa 405 is a precision, reliable and accurate All-Metal-Fixed-Dosage instrument, designed for mass treatment of fish.

This product is for use with feeding tube, that allows the injection of any kind of product for fish and small animals. All the components are made of the finest material, oil proof, noncorrosive; the valve is made of stainless steel ball. The piston slides smoothly along the metal cylinder. It is supplied with 2 pistons of 0.05cc and 0.1cc dosage. All parts can be sterilized up to 125°C.

Before Use:

1. It's recommended to sterilize the syringe before each use.
2. Check that all screwed parts are tightened.
3. Make sure that the valve springs and washers are properly positioned into the base.

To set the dose:

1. In the box find the key-pin (20).
2. Open the body-cover (13) by gripping it with your fingers and turn.
3. Press the piston - forward to its utmost position, and insert the key-pin into the hole on the piston.
4. Grip the piston and unscrew it, and change to the one you need.
5. Tight the new piston gently with the key-pin.
6. Take out the key-pin from the piston.
7. Put a drop of castor-oil on the piston's O-ring.
8. Close the body-cover and tight it.

Preparing the vial for vaccination:

1. Insert the long canula through the rubber cover; be sure to insert it down to the bottom of the vial.
2. Connect the plastic tube to the long canula, on one end, and to the syringe inlet on the other end.
3. Operate the syringe handle until the vaccine is being pumped from the vial up to the syringe.

Recommended:

Add small ordinary needle next to the long cannula to let the air penetrating into the vial. The ThaMa 405 is now ready for use.

Care and Maintenance after Use:

1. After each time that the syringe is being used, pump the syringe in clear water, 6-10 times, to remove any residue of the material from the body, needles, and tube (be careful not to get pricked by the needle).
2. Open the body-cover (13), and wash all the parts in clear water.
3. Open the luer lock needle adapter (02), and the tubing valve housing (03), and wash them in clear water.

Note:

Pay attention, and take good care not to lose the small parts, like valves, valve's springs, and valve's plastic washers.

